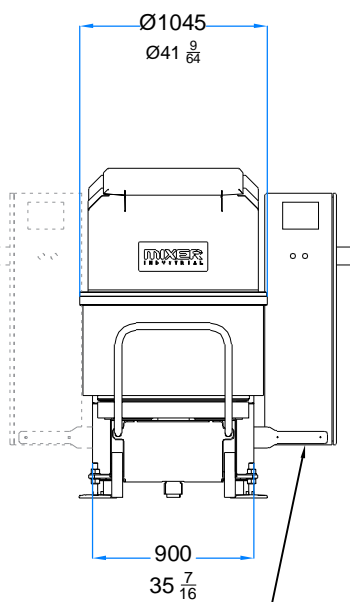
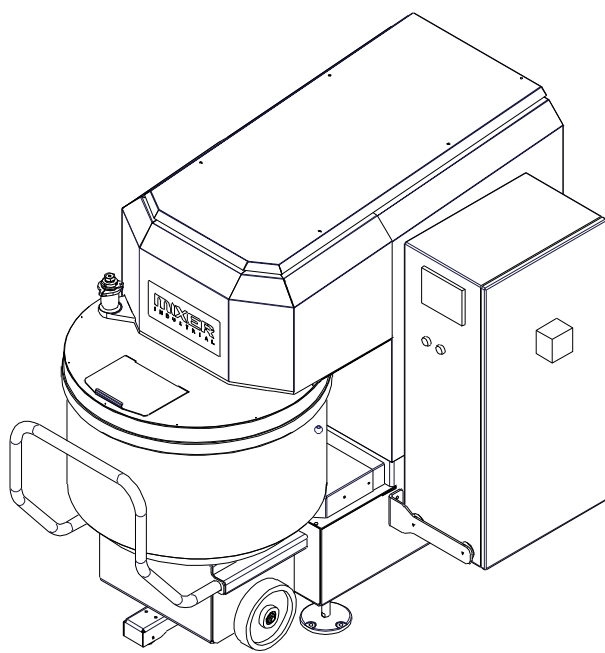
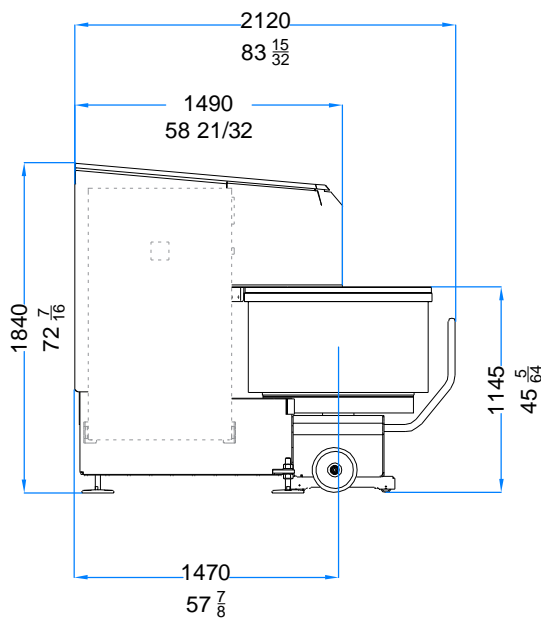
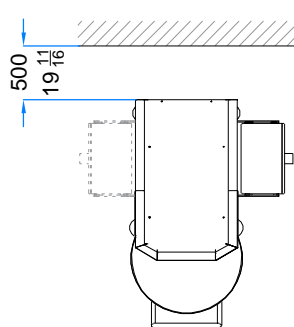
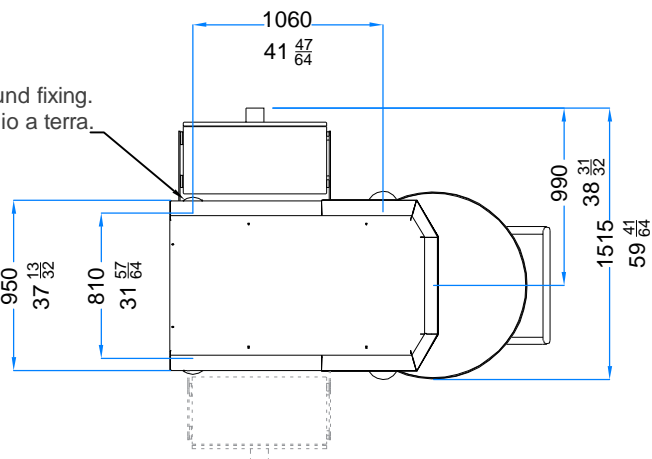

 Electric connection  
 Connessione elettrica

 Electric connection  
 Connessione elettrica

 (M16) Ground fixing.  
 Fissaggio a terra.

 Total installed power Kw 30  
 Potenza totale installata Hp 40

 Nominal current A 56  
 Assorbimento massimo

 Machine net weight Kg 2300  
 Peso netto macchina lb 5070

 Cart net weight Kg 340  
 Peso netto carrello lb 750

 Bowl volume Lt 420  
 Volume vasca gal 110

 Residual device switch must be in B-class  
 Necessario interruttore con protezione differenziale in classe B