

Electric connection  
Connessione elettrica

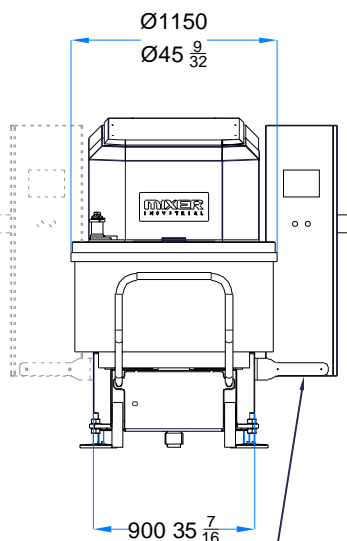

Electric connection  
Connessione elettrica

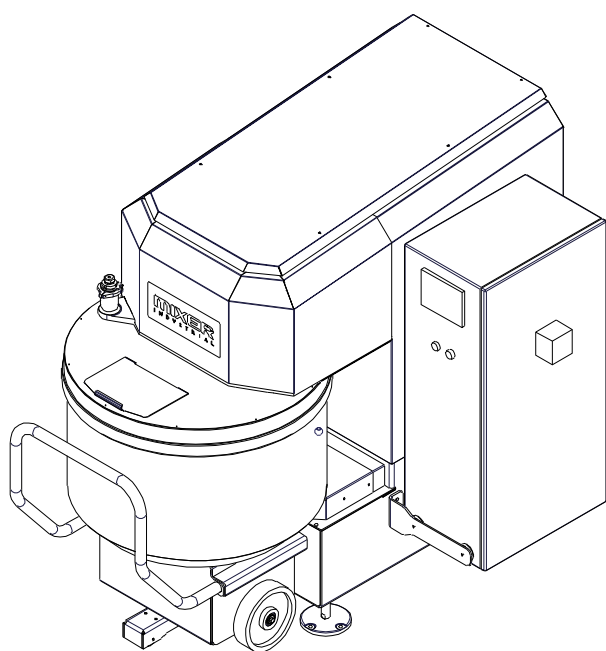
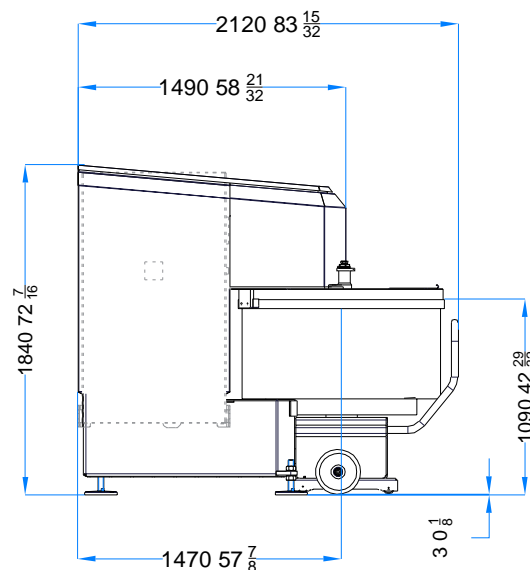

(M16) Ground fixing.  
Fissaggio a terra.

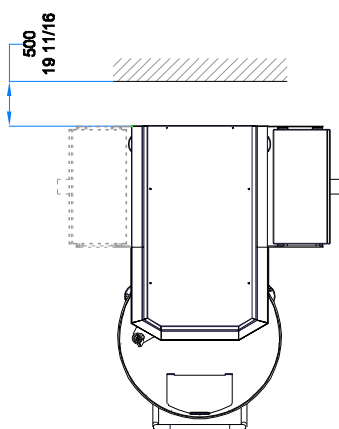
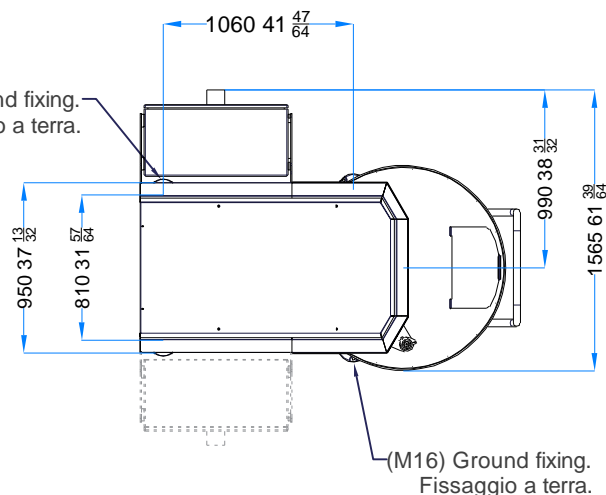

Total installed power Kw 33  
Potenza totale installata Hp 44

Nominal current A 62  
Assorbimento massimo

Machine net weight Kg 2350  
Peso netto macchina lb 5180

Cart net weight Kg 390  
Peso netto carrello lb 860

Bowl volume Lt 520  
Volume vasca gal 137

Residual device switch must be in B-class  
Necessario interruttore con protezione differenziale in classe B