

Electric connection
Connessione elettrica

Electric connection
Connessione elettrica

ONLY FOR AUTOMATIC PLANT

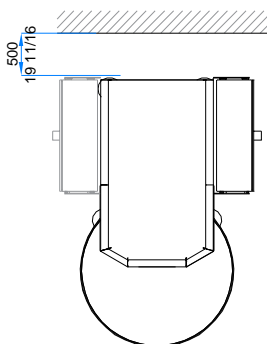
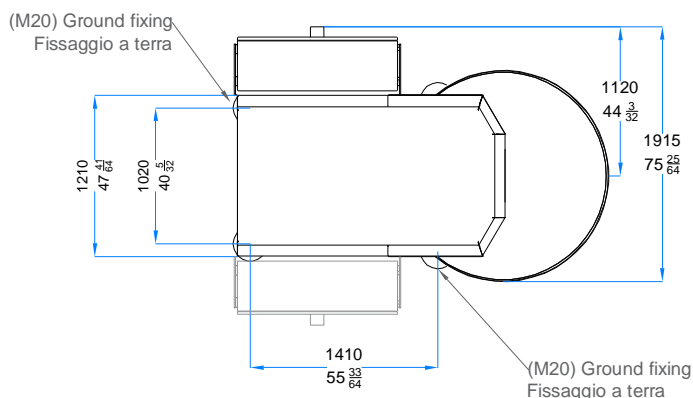
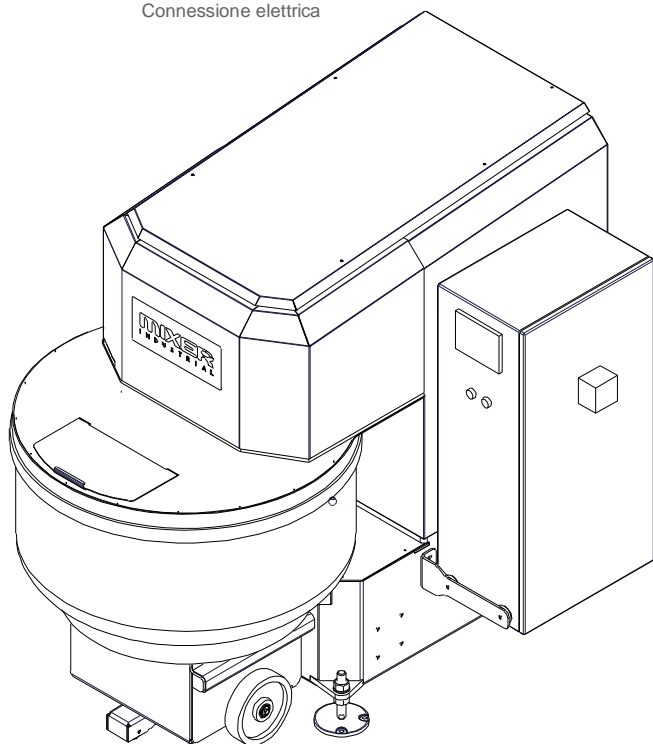

Total installed power Potenza totale installata	Kw 49 Hp 66
Nominal current Assorbimento massimo	A 92
Machine net weight Peso netto macchina	Kg 3900 lb 8598
Cart net weight Peso netto carrello	Kg 1000 lb 2200
Bowl volume Volume vasca	Lt 1200 gal 317

Residual device switch must be in B-class
Necessario interruttore con protezione differenziale in classe B