

ONLY FOR AUTOMATIC PLANT

Electric connection
Connessione elettrica

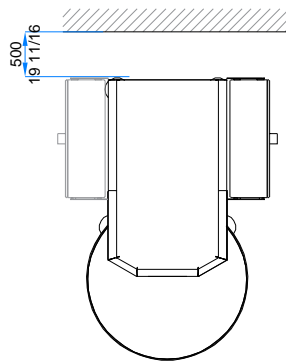
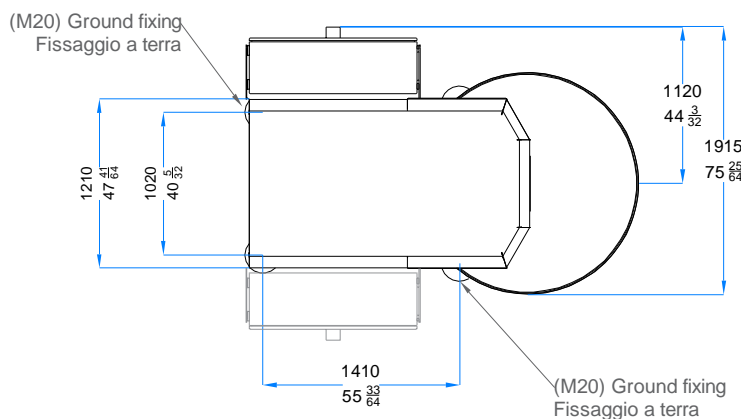
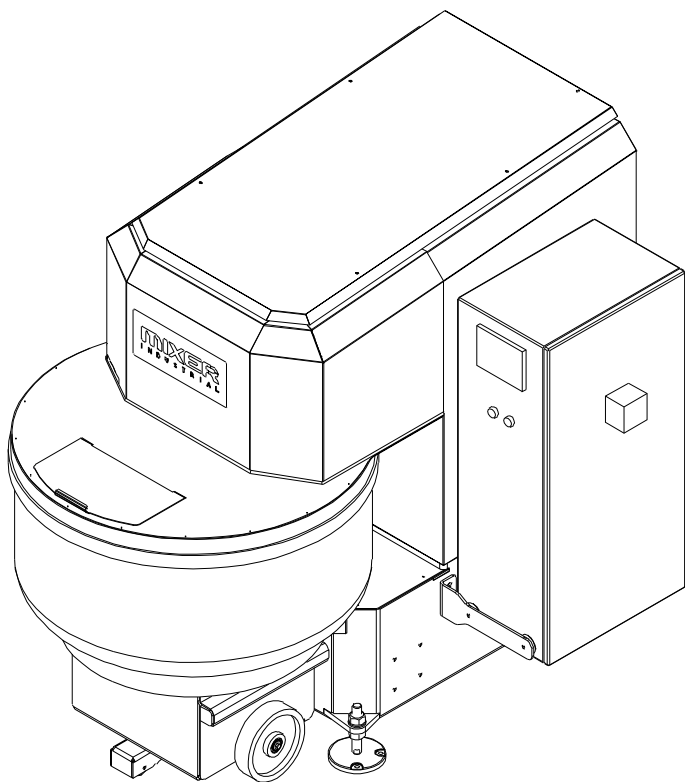

Total installed power Potenza totale installata	Kw 78 Hp 105
Nominal current Assorbimento massimo	A 145
Machine net weight Peso netto macchina	Kg 4200 lb 9259
Cart net weight Peso netto carrello	Kg 1000 lb 2200
Bowl volume Volume vasca	Lt 1200 gal 317

Residual device switch must be in B-class
Necessario interruttore con protezione differenziale in classe B